

TAKEUCHI

Those in the know, know Takeuchi

OPERATING PERFORMANCE

Operating Weight	Canopy 6,360 lbs (2,885 kg)
Maximum Digging Depth	9 ft 3.6 in (2,835 mm)
Maximum Dump Height	10 ft 7.2 in (3,230 mm)
Maximum Reach	15 ft 10.9 in (4,850 mm)
Maximum Bucket Breakout Force	6,471 lbs (2,935 kg)
Maximum Arm Digging Force	2,900 lbs (1,325 kg)
Arm Length	4 ft 9 in (1,445 mm)
Slew Speed	10.3 rpm
Traction Force	6,340 lbs (2,876 kg)

ENGINE

Make / Model	Yanmar / 3TNV88F
Tier Rating	EPA Final Tier 4
Cylinders / Displacement	3 / 81 cu in (1.3 L)
Horsepower	24.4 hp (18.2 kW)
Rated Engine Speed	2,400 rpm
Maximum Torque	63 ft-lb @ 1,440 rpm (85.3 Nm)
Engine Lubrication	5.0 qt (4.7 L)
Cooling System	4.2 qt (4.0 L)
Fuel Tank Capacity	14.0 gal (53.0 L)
Fuel Consumption (65% of full load)	0.8 gal / hr (3.3 L / hr)
Electrical System	12 volts / 40 amps

UNDERCARRIAGE

Traction Drive Type	Planetary Reduction w/ Automatic Shift
Parking Brake	Spring Applied, Hydraulically Released, Multiple Wet Friction Disc
Track Roller Type	Permanently Sealed, Triple Flanged Rollers
Track Rollers (per side)	3 per side
Track Width	11.8 in (300 mm)
Track Ground Contact Length	4 ft 8.7 in (1,440 mm)
Ground Pressure	4.3 psi (29.6 kPa)
Maximum Travel Speed	
Low Range	1.8 mph (2.9 km / hr)
High Range	3.2 mph (5.2 km / hr)

HYDRAULIC

Pump Type	Two Piston Pumps with Two Gear Pumps
Total Hydraulic Flow	24.2 gal / min (91.6 L / min)
Auxiliary Hydraulic Flow	13.4 gal / min (50.6 L / min)
System Operating Pressure	3,046 psi (21.0 MPa)
Hydraulic Reservoir Capacity	9.2 gal (35.0 L)
Hydraulic System Capacity	14.8 gal (56.0 L)



WORKING DIMENSIONS

A. Maximum Reach	15 ft 10.9 in (4,850 mm)
B. Maximum Reach Ground Level	15 ft 5.4 in (4,710 mm)
C. Blade Maximum Lower	12.2 in (310 mm)
D. Blade Maximum Lift	15.0 in (380 mm)
E. Maximum Dig Height	14 ft 7 in (4,450 mm)
F. Maximum Dump Height	10 ft 7.2 in (3,230 mm)
G. Maximum Dig Depth	9 ft 3.6 in (2,835 mm)
H. Maximum Vertical Dig Depth	7 ft 0.8 in (2,153 mm)

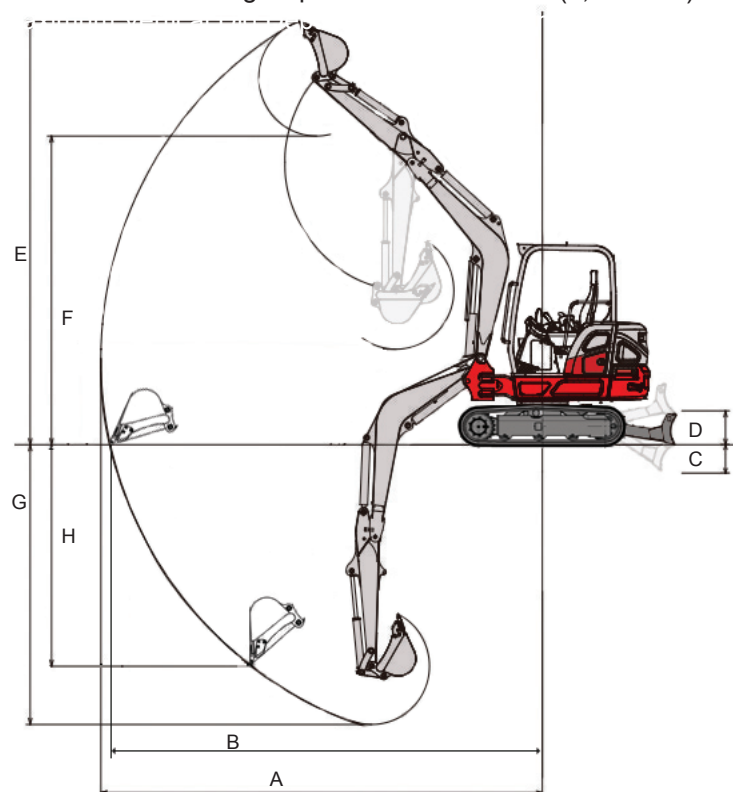

Product Features

ENGINE

- ◆ EPA Final Tier 4 Compliant
- ◆ Automatic Fuel Bleed System
- ◆ Extended Life Coolant
- ◆ Dual Element Air Filter
- ◆ Automatic Idle

ELECTRICAL

- ◆ Coolant Temperature and Fuel Level Gauge
- ◆ Audible and/or Visual Indicators for Battery Voltage, Engine Oil Pressure, Engine Coolant Temperature, Air Filter Restriction Indicator, High Speed Travel, Engine Preheat, One-Touch Idle
- ◆ 12 volt System with 40 amp Alternator
- ◆ Work Lights: Boom, Side Cover
- ◆ Engine Preheat
- ◆ Hour Meter
- ◆ Travel Alarm

UNDERCARRIAGE AND FRAME

- ◆ Triple Flanged Track Rollers
- ◆ Sloped Frame with Open Centers
- ◆ Two-Speed Travel with Automatic Shift
- ◆ Heavy Duty Dozer Blade with Float
- ◆ Cast Iron Wrap Around Protective Counterweight
- ◆ 11.8" Rubber Tracks
- Power Angle Blade with Float and Bolt On Cutting Edge that Angles 25° Right and Left
- 11.8" Steel Tracks

HYDRAULIC

- ◆ Cushioned Boom and Swing Cylinders
- ◆ Precise and Responsive Pilot Controls
- ◆ Proportional Slide Switch Control for Auxiliary Circuit
- ◆ Auxiliary Hydraulic Circuit Plumbed to Arm
- ◆ Selectable One-Way and Two-Way Auxiliary Operation
- ◆ Auxiliary Detent (Primary Circuit)
- ◆ Pilot Accumulator
- ◆ Large Hydraulic Reservoir with Fluid Level Sight Gauge

WORKING EQUIPMENT

- ◆ Main Boom Cylinder Guard
- ◆ Long Arm with Integrated Thumb Mount
- Dual Pin Position Bucket
- Mechanical Bucket Quick Coupler
- Main Pin Hydraulic Thumb

OPERATOR'S STATION

- ◆ ROPS / TOPS / FOPS Four Post Canopy
- ◆ Deluxe High Back Suspension Seat
- ◆ Adjustable Arm Rests
- ◆ Quick Change Control Pattern (ISO or SAE)
- ◆ 2" Retractable Seat Belt
- 3" Retractable Seat Belt

◆ - Standard ○ - Optional

MACHINE DIMENSIONS

A. Transport Length	15 ft 0.9 in (4,595 mm)
B. Transport Height	8 ft 3.9 in (2,540 mm)
C. Undercarriage Length	6 ft 2.9 in (1,900 mm)
D. Track Ground Contact Length	4 ft 8.7 in (1,440 mm)
E. Dozer Blade Height	14 in (355 mm)
F. Counter Weight Ground Clearance	1 ft 11.2 in (590 mm)
G. Tail Swing (Slew) Radius	4 ft 4.4 in (1,330 mm)
H. Dozer Blade Width	4 ft 9.5 in (1,460 mm)
J. Minimum Front Radius (Offset)	4 ft 11.2 in (1,505 mm)
K. Minimum Front Radius (Straight)	6 ft 2.7 in (1,895 mm)
L. Offset Working Distance (Right)	1 ft 7.3 in (490 mm) @ 58°
M. Offset Working Distance (Left)	1 ft 11.9 in (610 mm) @ 78°
P. Ground Clearance	11.9 in (305 mm)
Q. Track Width	11.8 in (300 mm)
R. Undercarriage Width	4 ft 9.5 in (1,460 mm)

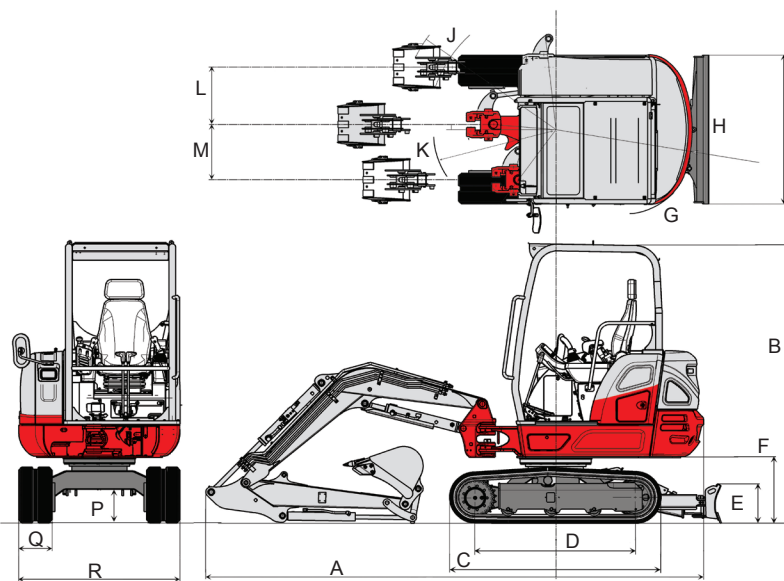

TAKEUCHI
Those in the know, know Takeuchi